

INSTALLATION INSTRUCTIONS

ACE LED TROFFER (AT2)

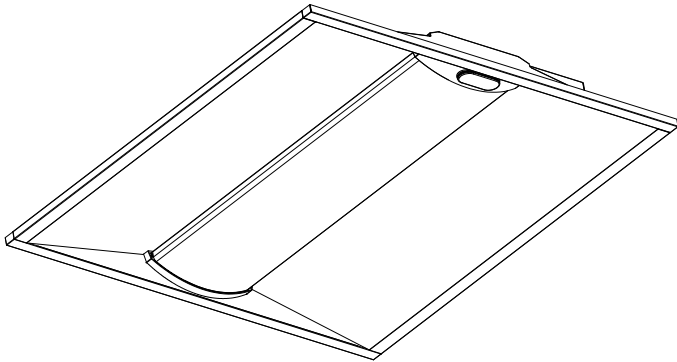

For any questions regarding wiring, installation or use of this product, please email techsupport@linmoreled.com or call 559-485-6010.



**READ CAREFULLY BEFORE
INSTALLING THE FIXTURE.**

PLEASE KEEP THIS MANUAL FOR FUTURE USE.

This luminaire must be installed in accordance with the NEC or your local electrical code. If you are not familiar with these codes and requirements, consult a qualified electrician.

IMPORTANT SAFEGUARDS

Read and follow all safety instructions

- **CAUTION** - Connect the fixture to a 120/277V, 50/60Hz power source. Any other connection voids the warranty.
- **WARNING** - To prevent wiring damage or abrasion, do not expose wiring to edges of sheet metal or other sharp objects.
- **WARNING** - Wear gloves when handling the fixture as edges are sharp.
- Do not make or alter any open holes in an enclosure of wiring or electrical components during installation.
- This luminaire is suitable for Damp locations. Prior to installation, review all environmental designation locations in the product spec sheet. Only install in damp locations if so indicated in the spec sheet.
- For dimming or lighting controls, use provided wiring diagram only.



WARNING

Risk of Fire or Electric Shock

- Before installation or servicing, turn the power OFF at the circuit breaker or fuse. Place tape over the circuit breaker switch and verify power is OFF at the light fixture.
- Ground the fixture to avoid potential electric shock.
- Do not handle energized module with wet hands or when standing on wet or damp surfaces, or in water.
- Luminaire wiring and electrical parts may be damaged when drilling for installation of LED troffer. Check for enclosed wiring and components.
- This product must be installed in accordance with the applicable installation code by a person familiar with the construction and operation of the product and the hazards involved.
- This product installation requires knowledge of luminaires electrical systems. If not qualified, do not attempt installation. Contact a qualified electrician.

TECHNICAL SPECS

Part No.	Watts	Input Voltage	PF	CCT	CRI	Dimmable	Warranty
AT20S-A2-ADJ-14-ADJ-80-FR-LV-GRID-EZ40-10V	20/30/40W	AC 120-277V	≥0.9	3500K/ 4000K/ 5000K	≥80	0-10V	5 Years
AT20S-A2-ADJ-22-ADJ-80-FR-LV-GRID-EZ40-10V	20/30/40W						
AT20S-A2-ADJ-24-ADJ-80-FR-LV-GRID-EZ40-10V	30/40/50W						

Ambient range operation: -20°C up to 35°C (-4°F up to 95°F)

SELECTING WATTAGE AND CCT

Use dip switches at the back of the fixture to select output power and color temperature.

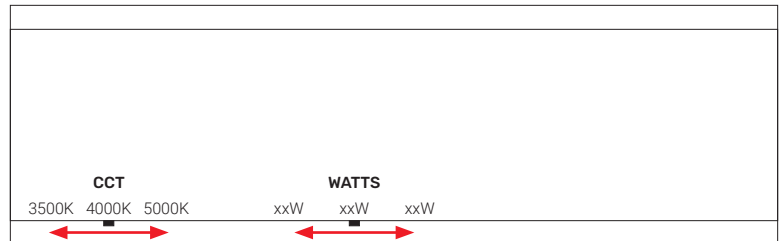

DIMENSIONS

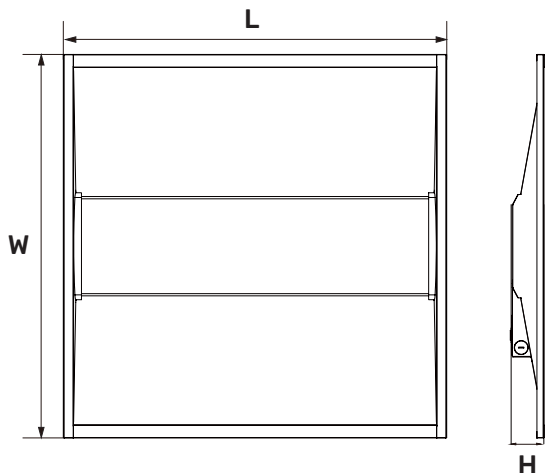

Size	L	W	H	Weight
1x4	47.76"	11.93"	1.97"	~6.3 lbs
2x2	23.74"	23.74"	1.97"	~5.3 lbs
2x4	47.76"	23.74"	1.97"	~8.8 lbs

Dimension tolerances: ± 0.1". Weights are approximate, if weight is a concern, please contact factory.

INSTALLATION GUIDE

SUPPLIED COMPONENTS

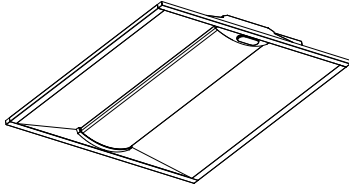

1x Fixture

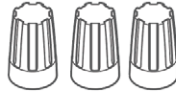

3x AA Wire Nuts



2x BB Wire Nuts

INSTALLATION

1

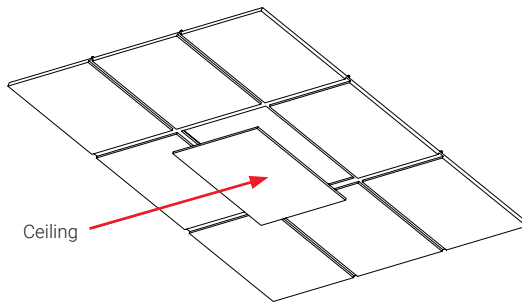

STEP 1

- Locate desired fixture location in ceiling grid.
- Remove existing ceiling panel at chosen location.
- Remove adjacent ceiling panel to allow for wiring access from above.

2

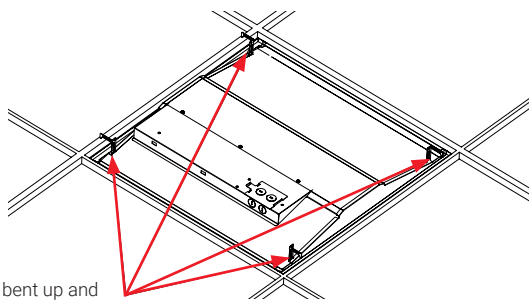

T-Bar clips bent up and rotated out to engage T-bar

STEP 2

- Place fixture into T-bar ceiling grid.
- Bend clips on top of fixture up and rotate out to engage with T-bar support grid.
- Secure fixture to grid in compliance with state and local codes.

3

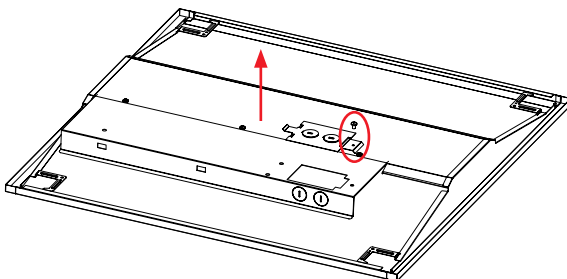

STEP 3

- Remove screw on driver wiring chamber and remove cover.
- Set screw and cover aside to be reinstalled later.

INSTALLATION GUIDE

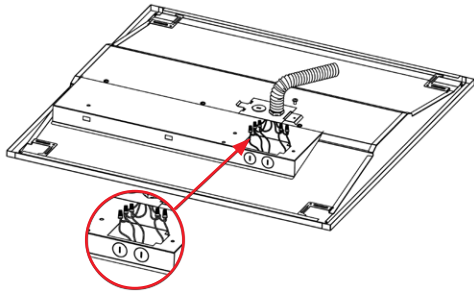
4**STEP 4**

- Remove appropriate 1/2" knockout(s) to allow for entry of supply wiring into wiring chamber.
- Wire luminaire per "Wiring Diagram" section and push all leads into the junction box.

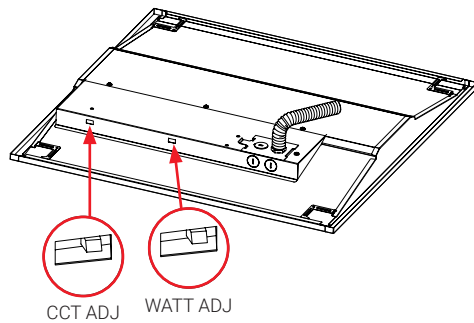
5**STEP 5**

- Reattach cover of wiring chamber with the screw that was removed in Step 4 above.
- Select CCT and Wattage with corresponding dip switches.

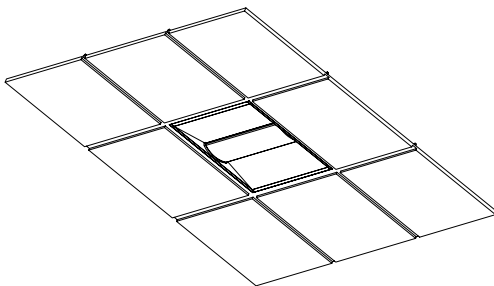
6**STEP 6**

- Replace adjacent ceiling panel removed in Step 2.
- Installation completed.

INSTALLATION GUIDE

WIRING DIAGRAM

Make the following electrical connections:

- A. Connect the black fixture lead to the voltage supply Line position, Hot.
- B. Connect the white fixture lead to the neutral supply position.
- C. Connect the green or green/yellow ground lead to the supply ground lead.
- D. If 0/1-10V Dimming is used, connect the violet lead to the supply positive dimming lead and connect the gray or pink lead to the supply negative dimming lead. If dimming is not being used ensure to cap off the violet lead and gray or pink lead.
- E. To install a sensor, remove the sensor cover and insert it directly into the EZ-Connect™ receptacle. If sensor is not in use, ensure cover is on.

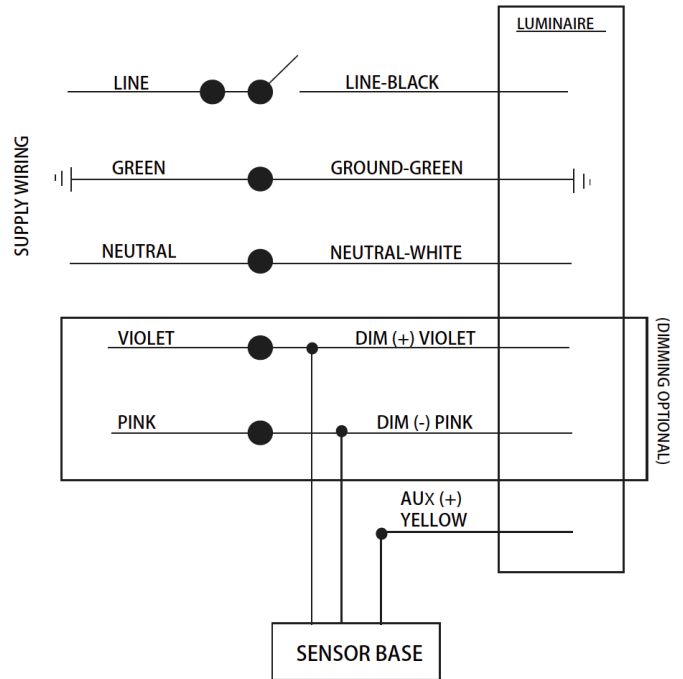

FCC NOTICE

CAUTION

- FCC Regulations state that any unauthorized changes or modifications to this equipment not expressly approved by the manufacturer could void the user's authorization to operate this equipment.
- The device is tested and found to comply with Part 15 of the FCC Rules. Operation is subject to two conditions: (1) This device may not cause harmful interference and, (2) this device must accept any interference received, including any interference that may cause undesired operation.
- This equipment has been tested and found to comply with the limits for a Class A digital device, pursuant to Part 15 of the FCC rules.
- These limits are designed to provide reasonable protection against harmful interference when the equipment is operated in a commercial environment.
- The equipment generates, uses, and can radiate radio frequency energy and, if not installed and used in accordance with the instruction manual, may cause harmful interference to radio communications.
- However, there is no guarantee that interference will not occur in a particular installation. If this equipment does cause harmful interference to radio or television reception, which can be determined by turning the equipment off and on, the user is encouraged to try to correct the interference by one or more of the following measures:
 1. Reorient or relocate the receiving antenna.
 2. Increase the separation between the equipment and receiver.
 3. Connect the equipment into an outlet on a circuit different from that to which the receiver is connected.
 4. Consult the dealer or an experienced radio/TV technician for help.

Conforms to standard CAN-ICES 005(A)/NMB-005 (A)