

## INSTALLATION INSTRUCTIONS

### ACE LED STRIP (AS2)

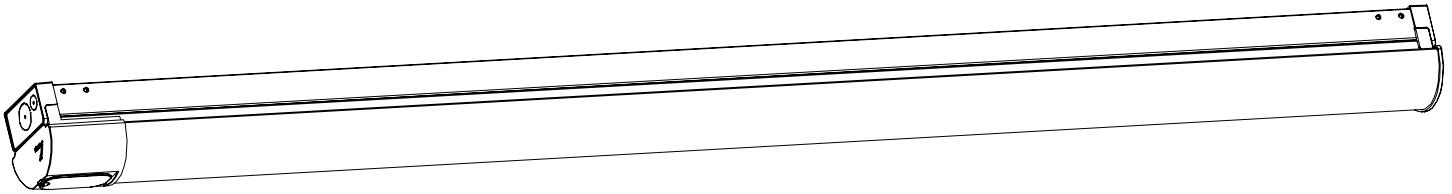

For any questions regarding wiring, installation or use of this product, please email [techsupport@linmoreled.com](mailto:techsupport@linmoreled.com) or call 559-485-6010.



**READ CAREFULLY BEFORE  
INSTALLING THE FIXTURE.**

**PLEASE KEEP THIS MANUAL FOR FUTURE USE.**

This luminaire must be installed in accordance with the NEC or your local electrical code. If you are not familiar with these codes and requirements, consult a qualified electrician.



#### **WARNING**

#### **Risk of Fire or Electric Shock**

- Before installation or servicing, turn the power OFF at the circuit breaker or fuse. Place tape over the circuit breaker switch and verify power is OFF at the light fixture.
- Ground the fixture to avoid potential electric shock.
- Do not handle energized module with wet hands or when standing on wet or damp surfaces, or in water.
- Luminaire wiring and electrical parts may be damaged when drilling for installation of LED troffer. Check for enclosed wiring and components.
- This product must be installed in accordance with the applicable installation code by a person familiar with the construction and operation of the product and the hazards involved.
- This product installation requires knowledge of luminaires electrical systems. If not qualified, do not attempt installation. Contact a qualified electrician.

### IMPORTANT SAFEGUARDS

#### Read and follow all safety instructions

- **CAUTION** - Connect the fixture to a 120/277V, 50/60Hz power source. Any other connection voids the warranty.
- **WARNING** - To prevent wiring damage or abrasion, do not expose wiring to edges of sheet metal or other sharp objects.
- **WARNING** - Wear gloves when handling the fixture as edges are sharp.
- Do not make or alter any open holes in an enclosure of wiring or electrical components during installation.
- This luminaire is suitable for Damp locations. Prior to installation, review all environmental designation locations in the product spec sheet. Only install in damp locations if so indicated in the spec sheet.
- For dimming or lighting controls, use provided wiring diagram only.

# TECHNICAL SPECS

Part No.	Watts	Input Voltage	PF	CCT	CRI	Dimmable	Warranty
AS20S-A2-ADJ-02-ADJ-80-FR-LV-FXT-EZ40-10V	10/15/20W	AC 120-277V	≥0.9	3500K/ 4000K/ 5000K	≥80	0-10V	5 Years
AS20S-A2-ADJ-04-ADJ-80-FR-LV-FXT-EZ40-10V	25/35/45W						
AS20S-A2-ADJ-08-ADJ-80-FR-LV-FXT-EZ40-10V	65/75/90W						

Ambient range operation: -20°C up to 40°C (-4°F up to 104°F)

## SELECTING WATTAGE AND CCT

Adjust the dip switches located on the driver inside the fixture to select output power and color temperature.

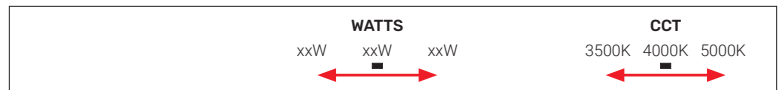

## DIMENSIONS

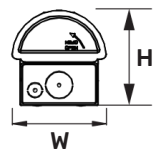
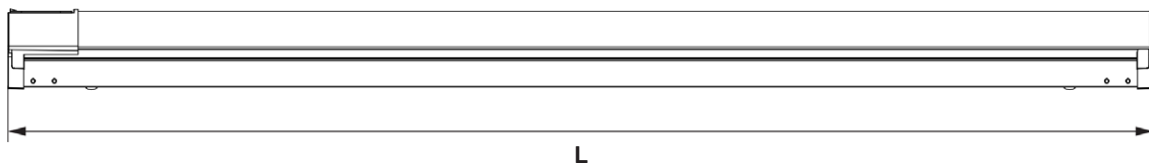

Size	L	W	H	Weight
<b>2ft</b>	23.94"	2.89"	2.95"	~1.6lbs
<b>4ft</b>	47.56"	2.89"	2.95"	~3.1lbs
<b>8ft</b>	94.80"	2.89"	2.95"	~6.2lbs

Dimension tolerances: ± 0.1". Weights are approximate, if weight is a concern, please contact factory.

# INSTALLATION GUIDE

## SUPLIED COMPONENTS

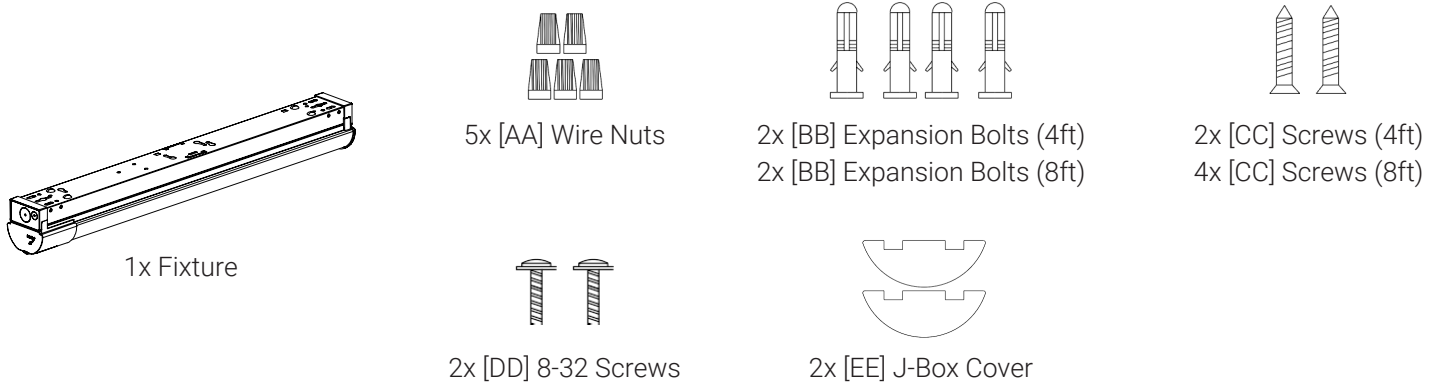

## INSTALLATION

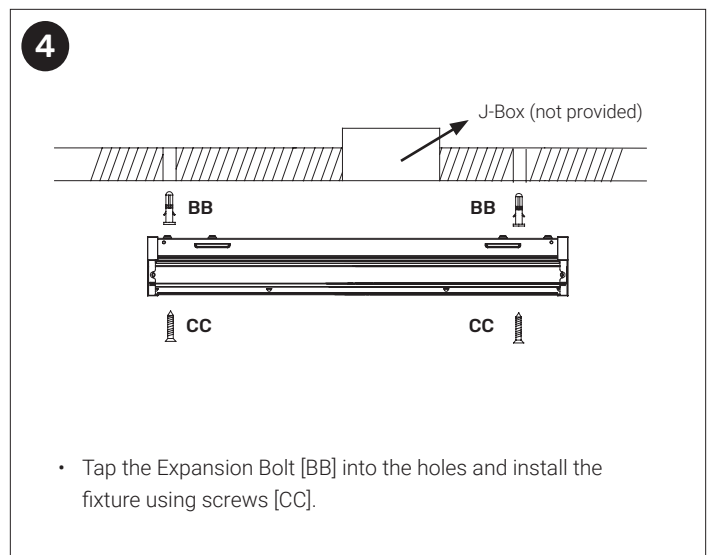
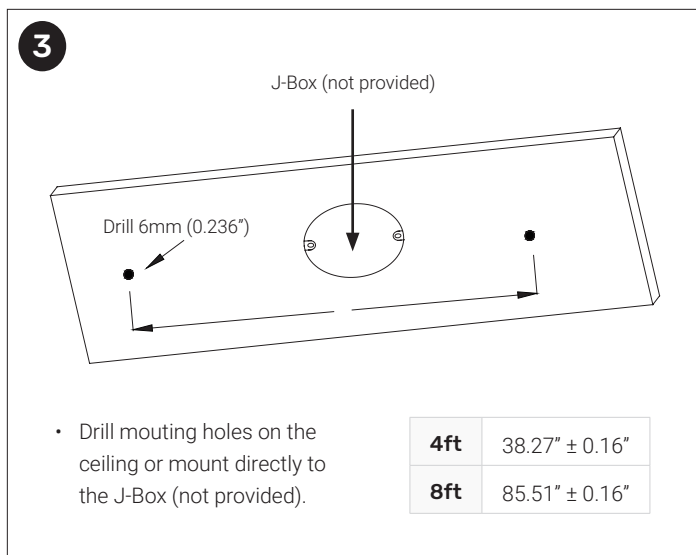
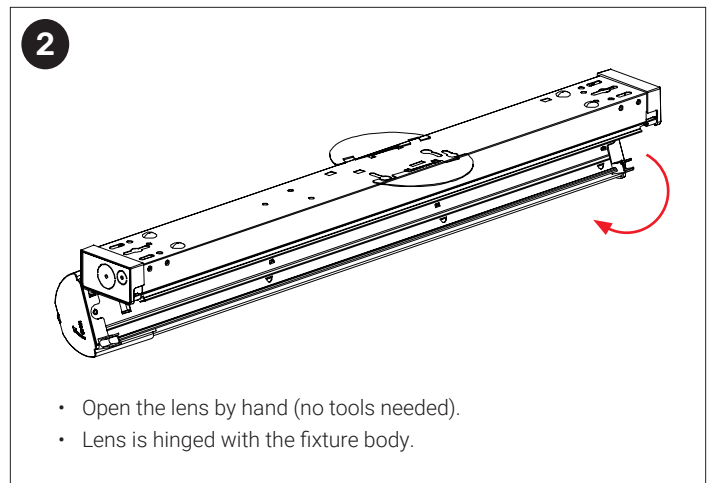
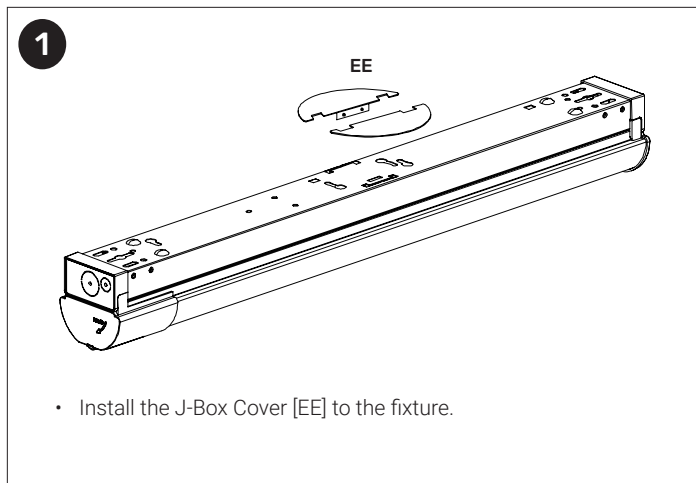

# INSTALLATION GUIDE

**5**

8-12mm (0.315-0.472")  
18-14 AWG

- Wire the fixture following the Wiring Diagram of this manual.
- Use Wire Nuts [AA] to secure wiring connections.

**6**

Dip switches inside

- Select CCT and Wattage by using dip switches.
- Close the fixture by re-attaching the lens to the body.
- Turn on the power at fuse or circuit box.

## WIRING DIAGRAM

Make the following electrical connections:

- Connect the black fixture lead to the voltage supply Line position, Hot.
- Connect the white fixture lead to the neutral supply position.
- Connect the green or green/yellow ground lead to the supply ground lead.
- If 0/1-10V Dimming is used, connect the violet lead to the supply positive dimming lead and connect the gray or pink lead to the supply negative dimming lead. If dimming is not being used ensure to cap off the violet lead and gray or pink lead.
- To install a sensor, remove the sensor cover and insert it directly into the EZ-Connect™ receptacle. If sensor is not in use, ensure cover is on.

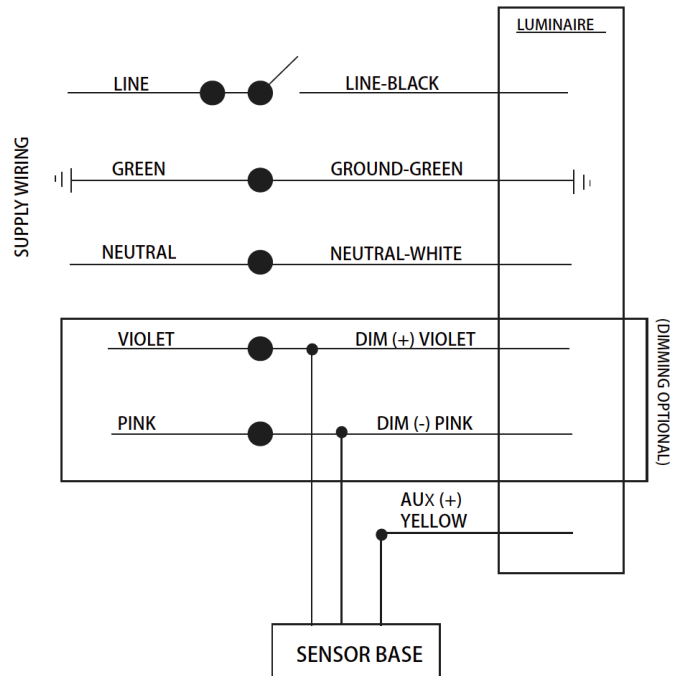

# INSTALLATION GUIDE

## JOINING TWO FIXTURES

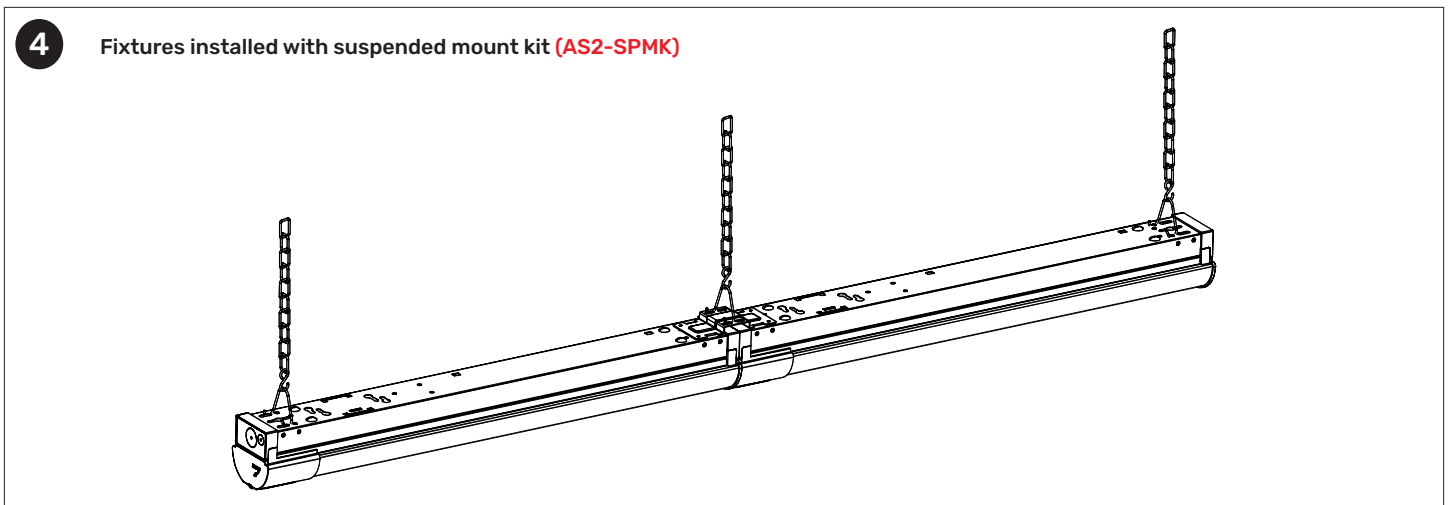
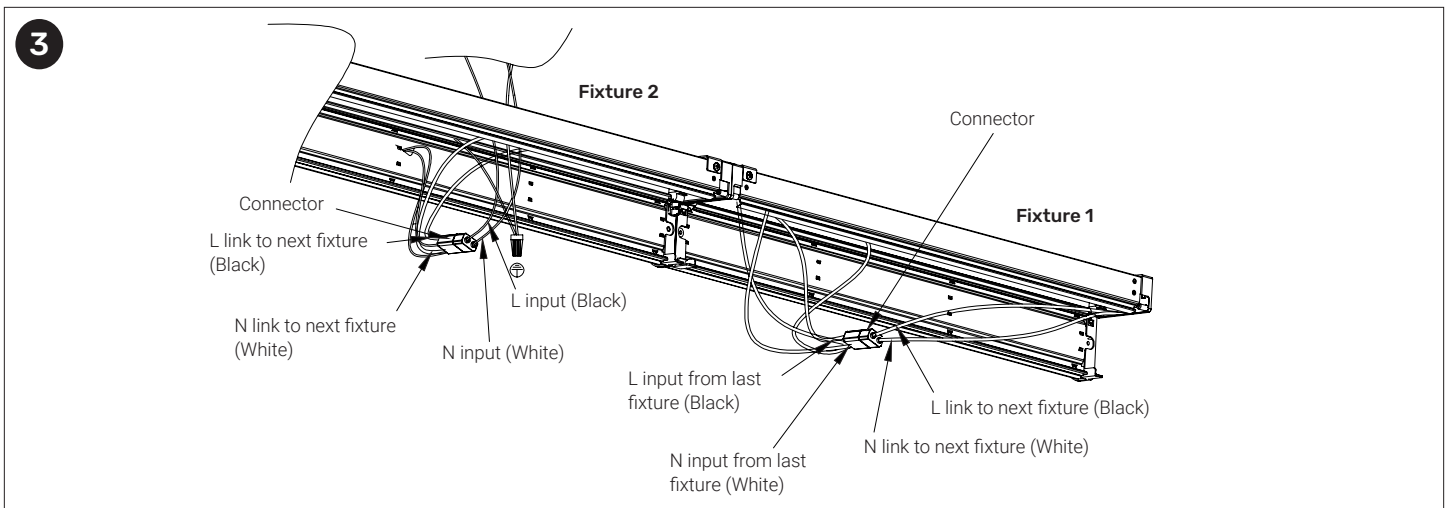
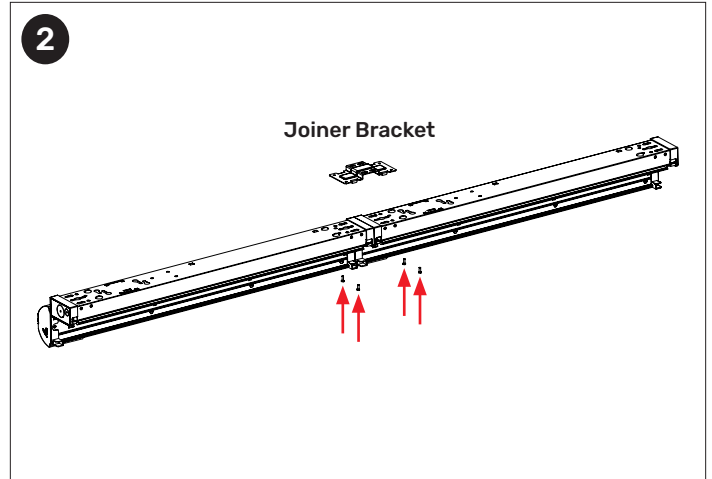
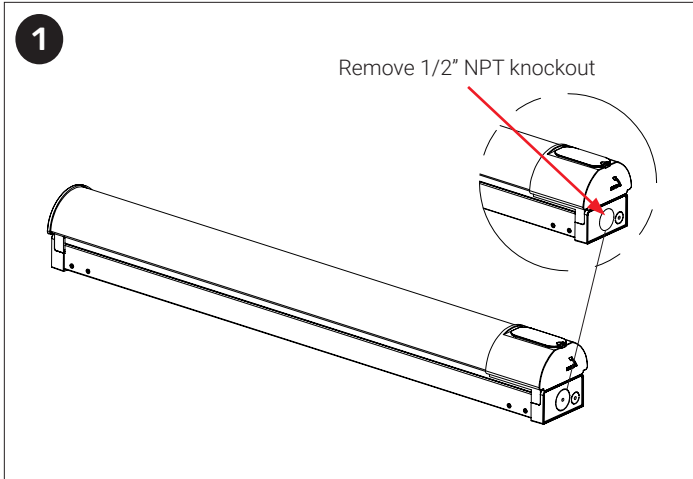

## FCC NOTICE

### CAUTION

- FCC Regulations state that any unauthorized changes or modifications to this equipment not expressly approved by the manufacturer could void the user's authorization to operate this equipment.
- The device is tested and found to comply with Part 15 of the FCC Rules. Operation is subject to two conditions: (1) This device may not cause harmful interference and, (2) this device must accept any interference received, including any interference that may cause undesired operation.
- This equipment has been tested and found to comply with the limits for a Class A digital device, pursuant to Part 15 of the FCC rules.
- These limits are designed to provide reasonable protection against harmful interference when the equipment is operated in a commercial environment.
- The equipment generates, uses, and can radiate radio frequency energy and, if not installed and used in accordance with the instruction manual, may cause harmful interference to radio communications.
- However, there is no guarantee that interference will not occur in a particular installation. If this equipment does cause harmful interference to radio or television reception, which can be determined by turning the equipment off and on, the user is encouraged to try to correct the interference by one or more of the following measures:
  1. Reorient or relocate the receiving antenna.
  2. Increase the separation between the equipment and receiver.
  3. Connect the equipment into an outlet on a circuit different from that to which the receiver is connected.
  4. Consult the dealer or an experienced radio/TV technician for help.

**Conforms to standard CAN-ICES 005(A)/NMB-005 (A)**